

GENERAL CHARACTERISTICS



Piston flow switch float measuring principle.
 The flow working range depends from the differential pressure generated in the flow chamber. The adjustment is very simple and the setting mechanism has a safe locking system.
 Electrical connection by DIN 43650-A plug.

- Flow visual indication
- High switch accuracy
- Hermetic separation of mechanical and electrical components
- Free installation position
- ATEX version available



TECHNICAL DATA

Tab.1

DN	Ø	Type	P max Bar	T max °C		Adjustable range l/min H2O	Code Range
				S	H		
020 025	3/4" 1"	VO.V1-020.GM VO.V1-025.GM	10	100	160	8 - 30	030 045 090
						15 - 45	
						30 - 90	
025	1"	VO.V1-025.GM	10	100	160	60 - 150	150

Adjustable ranges are indicated for horizontally decreasing flow

DN	Thread	UNI 228/1
Accuracy	± 10% F.S.	
Hysteresis	15% - minimum 0,5	
Pressure drop	0,02 to 0,4 bar	

MATERIALS

Tab.2

	GM	GK
Housing (*)	Anodized aluminium	Anodized aluminium
Sight glass	Duran® 50	Duran® 50
Piston/Piston	Brass	St. steel 1.4571
Spring/Spring	St. steel 1.4571	St. steel 1.4571

(*) non wetted part

ELECTRICAL DATA

Tab.3

Description	Characteristics				
Contact	Reed	N.A. SPDT(*)	250V	3,0A	100VA
			250V	1,5A	50VA
Electrical entry	Plug		DIN 43650-A	IP65	
			M12x1	IP67	

(*) minimum load 3V

DRAWING

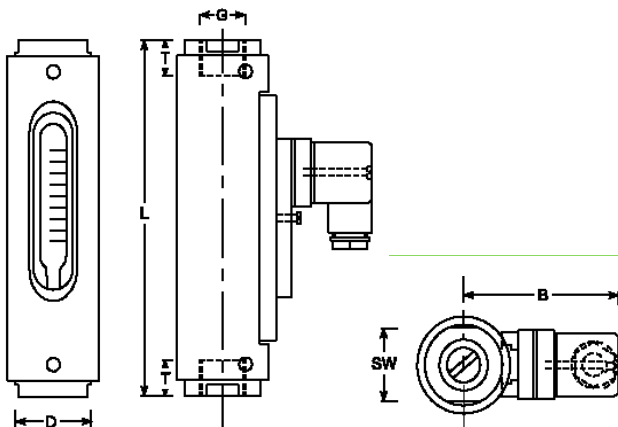

DIMENSIONS - mm

Range	DN	SW	D	B	T	L	Kg
030	020	41	50	77	18	139	0,80
	025					158	0,90
090	025	41	50	77	18	158	0,90

WIRING

Tab.4

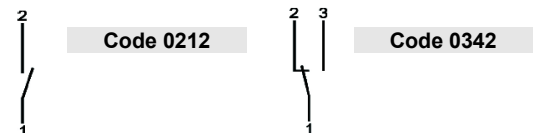

NOMENCLATURE

VO.V1	025	GM	090	IP65-S	0212
•					
	•				
		•			
			•		
				•	
					•

	Type
Tab.1	Dimensions Size and connections thread
Tab.2	Material
Tab.1	Adjustable range
Tab.1-3	Protection class – Temperature class
Tab.1	Wiring – Contact type