

Fig.904 Straight Through Sight Flow Indicator with Flap and Scale Plate - Gunmetal

The Fig.904 incorporates a pivoted internal flap (5), which provides indication of change in the rate of flow, from a drip to full flow.

FEATURES & BENEFITS

- The internal stainless steel flap (5) is electro polished to improve viewing in murky liquids.
- The indicators are suitable for both horizontal and vertical upward flows.
- A variety of glass and gasket materials are available as standard.

For product application please refer to pages 30 and 31.

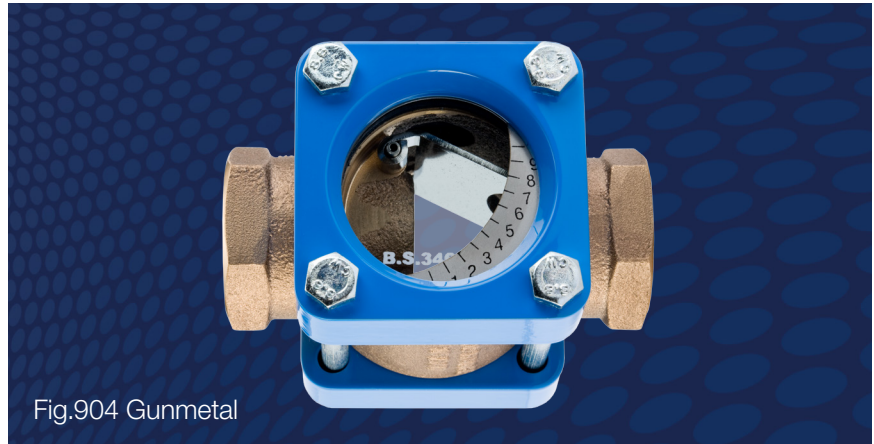

TEMPERATURE RATINGS

Max Pressure 16 Barg	Temperature
	-9.5°C to 200°C

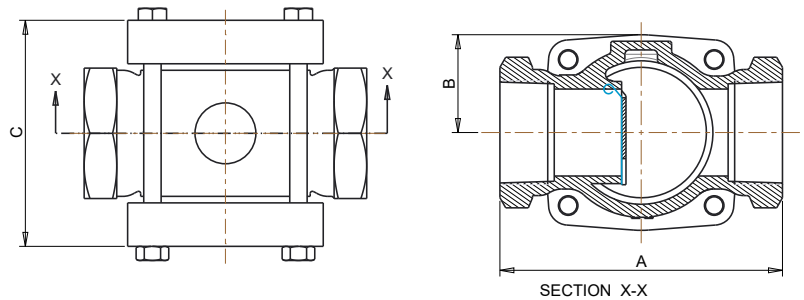

DIMENSIONS

Nominal Bore Size	Overall Length A (mm)	Max Height From Centre B (mm)	Max Width C (mm)
15	90	30	78
20	90	30	78
25	110	38	92
40	130	45	103
50	170	56	128

Every effort has been made to ensure that the information contained in this publication is accurate at the time of publishing. Rhodes assumes no responsibility or liability for typographical errors or omissions or for any misinterpretation of the information within the publication and reserves the right to change without notice.

MATERIALS OF CONSTRUCTION

ITEM NO.	DESCRIPTION	BODY MATERIAL	MATERIAL	QTY
1	Body	Gunmetal	BS EN 1982 CC491K	1
2	Cover	Mild Steel	BS EN 10025 S355J2G3	2
3	Glass Disc	Toughened Soda Lime	BS3463	2
		Borosilicate Glass	DIN 7080	
4	Spirol Pin	Spring Steel		2
5	Flap	Stainless Steel	SS316	1
6	Scale Plate	Aluminium		1
7	Nut	Mild Steel Zinc Plated		4
8	Bolt	Mild Steel Zinc Plated		4
9	Gasket	Nickel Reinforced Graphite		4
		PTFE		4

END CONNECTIONS

SCREWED

- BSP Taper Female 'Rc' BS EN 10226
- BSP Parallel Female 'Rp' BS EN 10226
- BSP Parallel Female 'G' ISO 228
- NPT Female

N.B. Fig. 904 is not available with flanged connections.

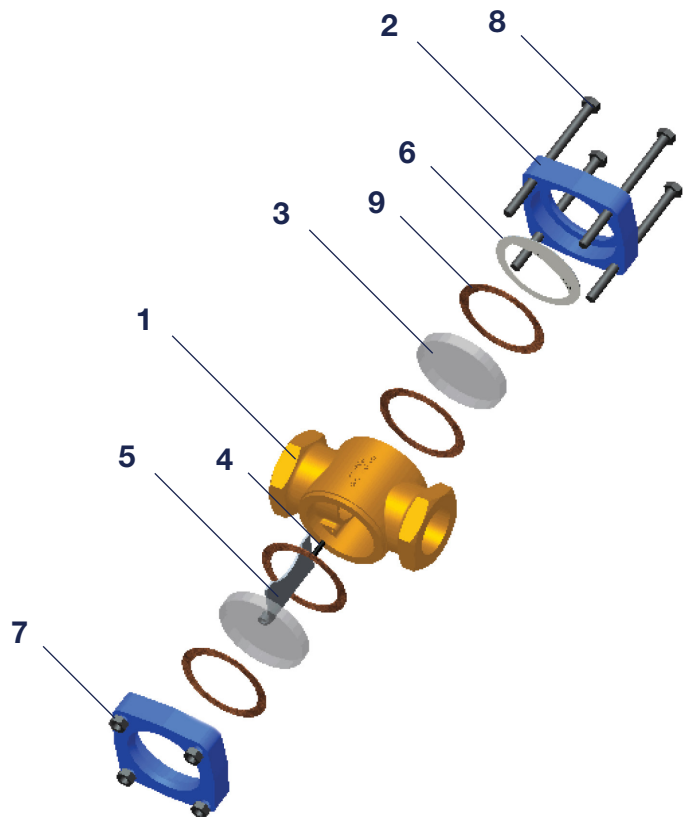

APPROVALS



FM00311 ISO 9001



ISO 14001 Reg No. EMS 78657

Every effort has been made to ensure that the information contained in this publication is accurate at the time of publishing. Rhodes assumes no responsibility or liability for typographical errors or omissions or for any misinterpretation of the information within the publication and reserves the right to change without notice.