

GENERAL CHARACTERISTICS



Piston flow switch float measuring principle.
 The flow working range depends from the differential pressure generated in the flow chamber. The adjustment is very simple and the setting mechanism has a safe locking system.
 Electrical connection by DIN 43650-A plug.

- **Low flow setting ranges**
- Flow visual indication
- High switch accuracy
- Hermetic separation of mechanical and electrical components
- Free installation position



TECHNICAL DATA Tab.1

DN	Ø	Type	P max Bar	T max °C		Adjustable range l/min H2O	Code Range
				S	H		
008	1/4"	VO.V4-008.GM	16	100	160	0,005 - 0,06	0001
						0,025 - 0,13	0002
						0,06 - 0,3	0003
						0,1 - 0,6	0006
						0,2 - 1,2	0010
						0,4 - 2	0020
						0,5 - 3	0030
						1 - 5	0050

DN	Thread	UNI 228/1
Accuracy	± 10% F.S.	
Hysteresis	15% - minimum 0,5	
Pressure drop	0,02 to 0,2 bar	

Adjustable ranges are indicated for horizontally decreasing flow

MATERIALS Tab.2

	GM	GK
Housing (*)	Anodized aluminium	Anodized aluminium
Sight glass	Duran® 50	Duran® 50
Piston	Brass	St. steel 1.4571
Spring	St. steel 1.4571	St. steel 1.4571

(*) non wetted part

ELECTRICAL DATA Tab.3

Description	Characteristics				
Contact	Reed	IP65	200V	1,0A	20VA
		IP67	125V	1,0A	20VA
Electrical entry	Plug	IP65	DIN 43650-A		
		IP67	M12x1		

DRAWING

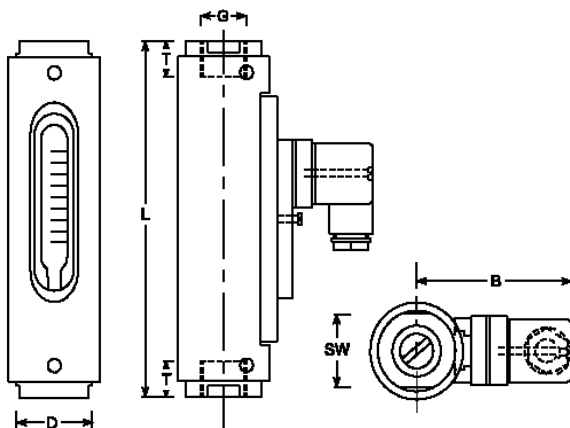

DIMENSIONS - mm

DN	SW	D	B	T	L	Kg
008	17	20	49	10	90	0,15

WIRING Tab.4

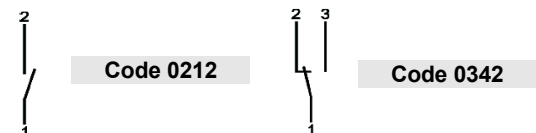

NOMENCLATURE

VO.V4	008	GM	0002	IP65-S	0212
•					
	•				
		•			
			•		
				•	
					•

	Type
Tab.1	Dimensions Size and connections thread
Tab.2	Material
Tab.1	Adjustable range
Tab.1-3	Protection class – Temperature class
Tab.4	Wiring – Contact type