

GENERAL CHARACTERISTICS



The magnetic trap filters are composed of a body that houses a filtering basket made of stainless steel, inside which is mounted a magnetic assembly. The basket filter traps any impurities in general, while the magnetic candle traps the ferrous particulate. The basket and the magnetic assembly can be easily inspected by removing the cap on the filter body.

This accessory is recommended to protect the flow switches piston where the presence of iron impurities may be origin of malfunction.



- Combined filtration with separator of ferrous particulate
- Easy maintenance and cleaning.
- Simple and efficient protection in hydraulic circuits.

TECHNICAL DATA

Tab.1

| Ø | Type – DN | P max bar | T max °C | Q max m³/h | ΔP bar a Q max | Mesh µm | H | L | H1 | SW | SW1 | X | Weight Kg |
|--------|-----------|-----------|----------|------------|----------------|---------|-----|-----|-----|-----|-----|----|-----------|
| 1/2" | ZV-015 | 16 | 150 | 2,3 | 0,15 | 600 | 42 | 66 | 84 | 25 | 22 | 11 | 0,30 |
| 3/4" | ZV-020 | 16 | 150 | 2,7 | 0,15 | 600 | 50 | 77 | 100 | 31 | 27 | 14 | 0,40 |
| 1" | ZV-025 | 16 | 150 | 4,4 | 0,15 | 600 | 62 | 90 | 124 | 38 | 32 | 14 | 0,65 |
| 1.1/4" | ZV-032 | 16 | 150 | 5,1 | 0,15 | 600 | 78 | 112 | 156 | 47 | 41 | 16 | 1,05 |
| 1.1/2" | ZV-040 | 16 | 150 | 7 | 0,15 | 600 | 82 | 120 | 164 | 54 | 46 | 16 | 1,40 |
| 2" | ZV-050 | 16 | 150 | 11,9 | 0,15 | 600 | 95 | 150 | 190 | 66 | 56 | 20 | 2,20 |
| 2.1/2" | ZV-065 | 16 | 150 | 18,4 | 0,15 | 600 | 125 | 220 | 250 | 85 | 70 | 22 | 3,80 |
| 3" | ZV-080 | 16 | 150 | 30 | 0,15 | 600 | 140 | 250 | 280 | 100 | 75 | 25 | 5,80 |

Measures in mm. see Tab.3

| | | |
|----------|--------------------|---|
| Thread Ø | Parallel UNI 228/1 | G |
|----------|--------------------|---|

MATERIALS

Tab.2

| DN | Standard All sizes | Option 015 – 020 – 025 |
|-------------------|--------------------|------------------------|
| Body | Bronze Rg5/Rg6 R | Brass O |
| Magnetic assembly | Barium-Ferrite | Barium-Ferrite |
| Filtering basket | S.S AISI-304 | S.S. AISI-304 |
| Sealing gasket | Copper | Without asbestos fiber |

DIMENSIONS mm.

Tab.3

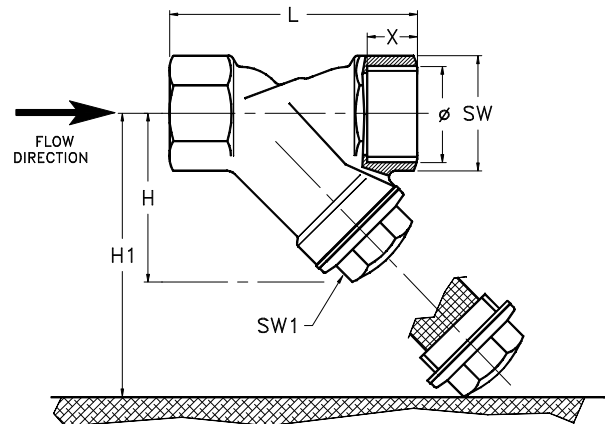

NOMENCLATURE

| | | | |
|----|-----|-----|-----|
| ZV | 040 | G R | 600 |
| • | | | |
| | • | | |
| | | • | |
| | | | • |

| | |
|---------|-------------------------------|
| - | Name - Type |
| Tab.1 | Process connection dimensions |
| Tab.1-2 | Body material and thread |
| Tab.1 | Filtration grade |