

TOSHIBA ELECTROMAGNETIC FLOWMETERS

These flowmeters will accurately measure the flow of any conductive liquid including chemicals, foods, process waste and slurries.

No moving parts ✓

- No obstruction to flow
- No wear - low maintenance
- Suspended solids? No problem!

Easy to use ✓

- Displays flow rate and total
- Outputs for your control system
- Preset for your application

Accurate measurement of flow ✓

- Improve quality
- Wide flow range
- Unaffected by viscosity changes

High quality product ✓

- Very reliable, stable and robust
- Chemically resistant lining



Application

These flowmeters are ideal for all conductive liquids including aggressive, abrasive and corrosive chemicals, hygienic liquids and liquids containing solids. Typical applications include the measurement of pharmaceuticals, chemicals, pulps, foods, acids, alkalis, dyes and waste water. The accuracy is not affected by changes in pressure, temperature, density, conductivity or viscosity. The flowmeter will accurately measure uneven flows.

Output

An LCD displays the flow rate and the total. There is also a 4-20mA analogue and two pulsed signals for transmitting to control systems or remote instruments. There are options for high and low flow alarms, empty pipe detection, preset point output, multi-range selection and forward and reverse flow detection.

The outputs are HART compatible for remote communication.

Construction

The meter is made up of a detector and display which you can mount either together or separately. There is no obstruction to flow so any solids simply pass through and the pressure drop is very low. The technology used gives outstanding accuracy, stability and reliability. A build up of deposits on the

electrodes has no effect on the readings provided some part of the electrode is exposed.

Calibration

To increase accuracy the operating range can be set to any value between the minimum and maximum flow ranges. A test certificate is issued for each flowmeter and the display and outputs are preset to your requirements.

Installation

The flowmeter detector is mounted in the line and should be maintained full of liquid. It should be installed with ten straight pipe diameters upstream.

The combined model has an integral detector and display. The separate model allows you to mount the display away from the detector.

Principle of Operation

The measuring principle is based on Faradays Law of Electromagnetic Induction which states that if an electrical conductor, in this case the measured liquid, passes through a magnetic field an electromotive force (EMF) is induced perpendicular to the field and flow. This EMF is proportional to the average flow velocity and is detected by two electrodes mounted in the detector. The signal is conditioned by the converter to display the flowrate.

Display and output specification



Combined Display

Converter Specification

Display:	2 line 16 character dot matrix backlit LCD display
Current output:	4-20mA (max load 1 k Ω)
Digital output DO1:	Transistor open collector
Capacity:	Maximum 30V dc 200mA
Digital output DO2:	Solid state relay
Capacity:	Max 150V dc 150 mA
Pulse output:	(DO1 only) 3.6-3600000 pulses/hour. Pulse width of 0.5 - 500 ms
DO1 or DO2 can be used for the following:	
Flow alarm output:	High and low limit alarm
Empty pipe output:	Alarm output for empty pipe
Preset point output:	Output signal for when a preset quantity has been reached
Digital input:	20 - 30 V dc signal
Digital input can be set for:	
Multi range:	4-range switching to increase accuracy
Totaliser control:	Start, stop and reset totaliser
Communications:	A digital signal conforming to the HART protocol is superimposed on the 4-20mA signal
Protection:	IP67 (NEMA4)
Temp range:	-10 to +60 °C

Materials of Construction

Converter case:	Aluminium alloy
Coating:	Pearl-grey acrylic resin
Cable connection:	11-13mm cable gland

Power Supply

Mains:	100 to 240 V ac 50/60 Hz
DC:	24 V dc (allowable 20.4 -28.8V)
Surge protection:	Surge protectors are installed in the power supply and current signal output circuits.
Power consumption:	Approx. 15W

Configuration

Settings:	The instrument is preset by Apollo for your application
Adjustments:	Changes can be made to the original setup by using the LCD display and three buttons below the display or by using a HART communicator

Specifications

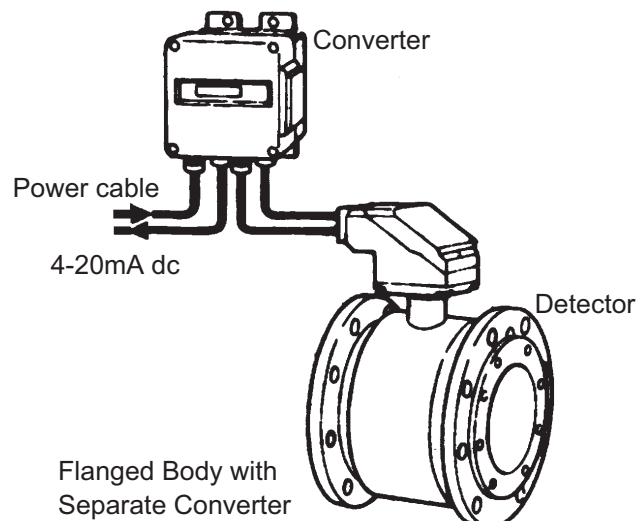
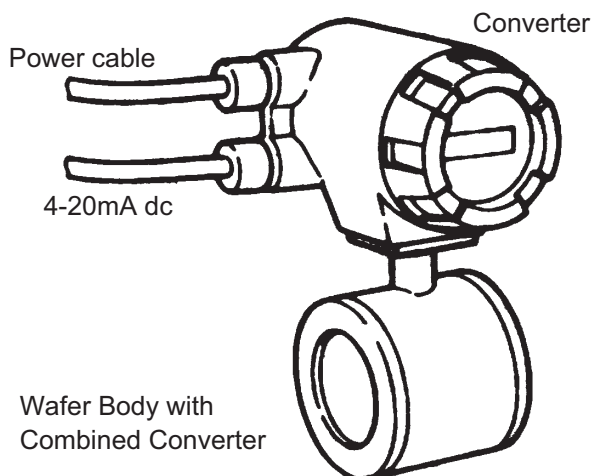

Flowmeter Performance

Size mm	Minimum flow range (0-0.3 m/s) litres/min	Maximum flow range (0-10m/s) litres/min
15	0-3	0-100
25	0-9	0-300
40	0-23	0-750
50	0-35	0-1200
80	0-90	0-3000
100	0-140	0-5000
150	0-320	0-10000
200	0-560	0-20000
250	0-880	0-30000
300	0-1300	0-40000
350	0-1700	0-58000
400	0-2300	0-75000

Accuracy

Flow rate as a %age of rate	Accuracy	
	0.3-1.0 m/s	1.0-10 m/s
0-20%	-	+/-0.1% full scale
20-100%	-	+/-0.5% of rate
0-50%	+/-0.25% full scale	-
50-100%	+/-0.5% of rate	-

Detector Specification

- Size: 15 to 400 mm diameter
- Flow velocity: Lowest range 0 to 0.3 m/s
Highest range 0 to 10 m/s
- Fluid pressure: Up to the flange rating
- Fluid temperature: -10 to 80 °C for chloroprene rubber lined
-10 to 120°C PTFE
- Accuracy: See the table below left
- Conductivity: Minimum 5µS/cm required
- Connections: Wafer 15 - 150mm
Flanges for 15 - 400mm
- Flange Specs: ANSI150,300 ND16,40

Materials of Construction

- Lining: PTFE for 15 to 200mm
80-400mm EPDM (std)
- Electrodes: 316 s/s (standard)
- Grounding rings: 316 s/s (standard)
- Measuring tube: 316 s/s
- Detector case: C/S for all flanged meters
- Detector coating: Resin coated
Resin for C/S
- Optional materials for the electrodes and grounding rings:
Hastalloy C, tantalum, titanium, 316L S/S and platinum / iridium

Installation Dimensions

Wafer Body Dimensions

Size mm	Dimensions			Weight kg
	L mm	H mm	C mm	
15	70	340	83	5
25	80	350	88	6
40	100	355	88	7.5
50	110	370	93	9
80	110	422	130	10
100	120	452	145	12
150	160	522	180	19

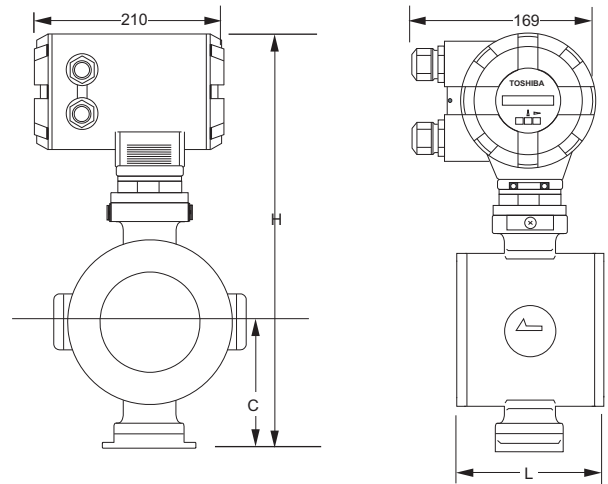

Size mm	L mm	H mm	C mm	Weight kg
15	140	348	83	7
25	160	358	88	9
40	170	363	88	12
50	180	378	93	14
80	230	430	130	20
100	240	460	145	25
150	260	530	180	44
200	300	575	175	70
250	350	645	210	100
300	400	705	245	130
350	450	760	270	180
400	500	825	305	230

Flanged Body Dimensions

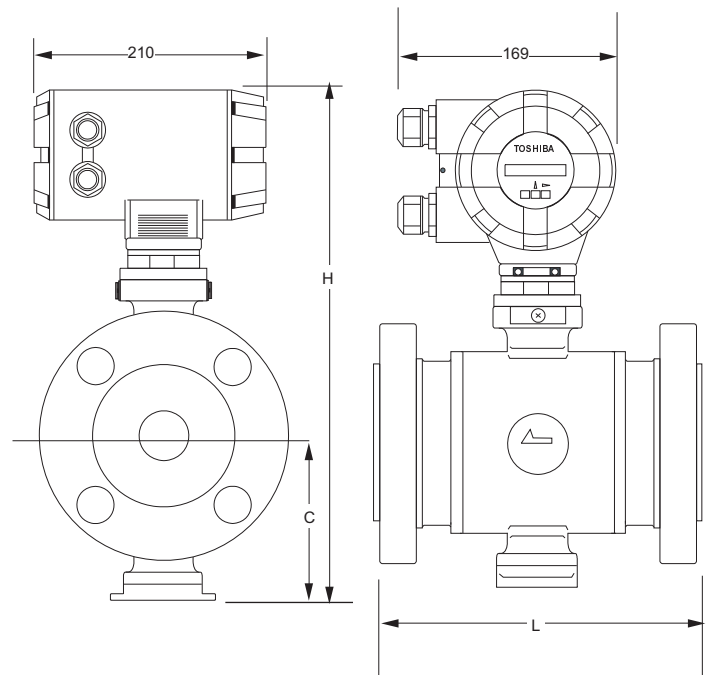

Contact our flow measurement specialists for advice on your application

Tel: 01922 645647

Fax: 01922 640326

e:mail sales@apolloflow.co.uk

website www.apolloflow.co.uk

Very reliable,
Stable,
Robust

Apollo Flowmeters, Charles Street, Walsall, WS2 9LZ

APOLLO

