

Ajax

Series **XP** FLAMEPROOF FLOAT LEVEL ALARM

CE
0518



I M2 / II 2G
EExd I / IIB + H₂ T6

- **SIRA** Certificate No: 03ATEX1507 Issue 1
EU Directive 94/9/EC (ATEX Directive)
CENELEC EN 50014, EN50018
(Zones 1 and 2 Hazardous Areas)

- **Versatility of Switching Circuits.**
- **Rugged Construction, Vibration and Shock Resistant.**
- **Side or Top Mounted.**
- **Weatherproof Enclosure in BS EN 1982 LG2/LG4 or Stainless Steel BS 3100 316C16.**
Environmental Protection Approval to IP66 according to IEC-144.

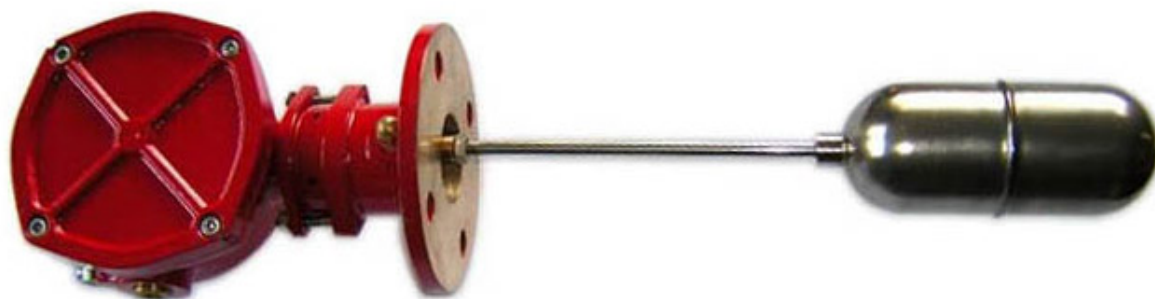

The Bamford Ajax XP series of Flameproof Float Level Alarm Switches are a new generation of ruggedly constructed devices for automatic control and reliable protection against dangerously high or low liquid levels in a tank, container or reservoir. The functionally designed enclosure is standard on all models to meet the arduous conditions experienced in the Petro-Chemical, Offshore and Mining industries. Single or double cable entries are available for fitting with approved cable glands. The standard precision snap action micro-switch is a single pole double throw type; however, one or two microswitches with silver plated noble metal contacts may be fitted to provide versatility of switching circuits.

The units are supplied with either a synthetic or stainless steel float and a lever arm length to suit requirements. In operation, the eccentrically mounted float arm activates, via a special "bellows" type seal, an internally adjustable microswitch. This allows for the device to be mounted at any liquid level without fear of leakage. The all-metal wetted parts cater for the majority of liquids.

F. Bamford (Instruments) Ltd.

Ajax Works,
Whitehill,
Stockport, SK4 1NT. United Kingdom.

Telephone: 0161-480 6507

Fax: 0161-474 7990

Web: www.bamfordinstruments.com
Email: sales@bamfordinstruments.com

Specifications

SWITCH RATING (STANDARD)

VOLTS	DC		AC	
	RES	IND	RES	IND
30	10A	10A	10A	10A
125	0.5A	0.07A	10A	10A
250	0.25A	0.03A	10A	10A

Alternative switches may be fitted for 440 volts or intrinsic safe circuits.

Conduit entry

Either one or two M20 or M25 x 1.5 pitch.

Connector size: 0.5mm² - 2.5mm²

Earthing screw: M5.

Ambient temperature range

of switch enclosure:

-20°C to +40°C

Maximum operating temperature

range of working medium:

-10°C to +93°C

Switch housing:

Manufactured in either:

Gunmetal BS EN 1982 LG2/LG4

Stainless Steel BS EN 3100 316C16

Wetted parts:

Phosphor Bronze PB1 BS 2870 /

Gunmetal BS EN 1982 LG2/LG4

Float material:

Stainless Steel 316 or Polypropolene

Maximum Working Pressure:

10 Bar G

Tank Mounting

40mm NB BST 'D' (Standard)

Alternative Flanges Available

Dimension Drawing



Certificate No: FM 13215

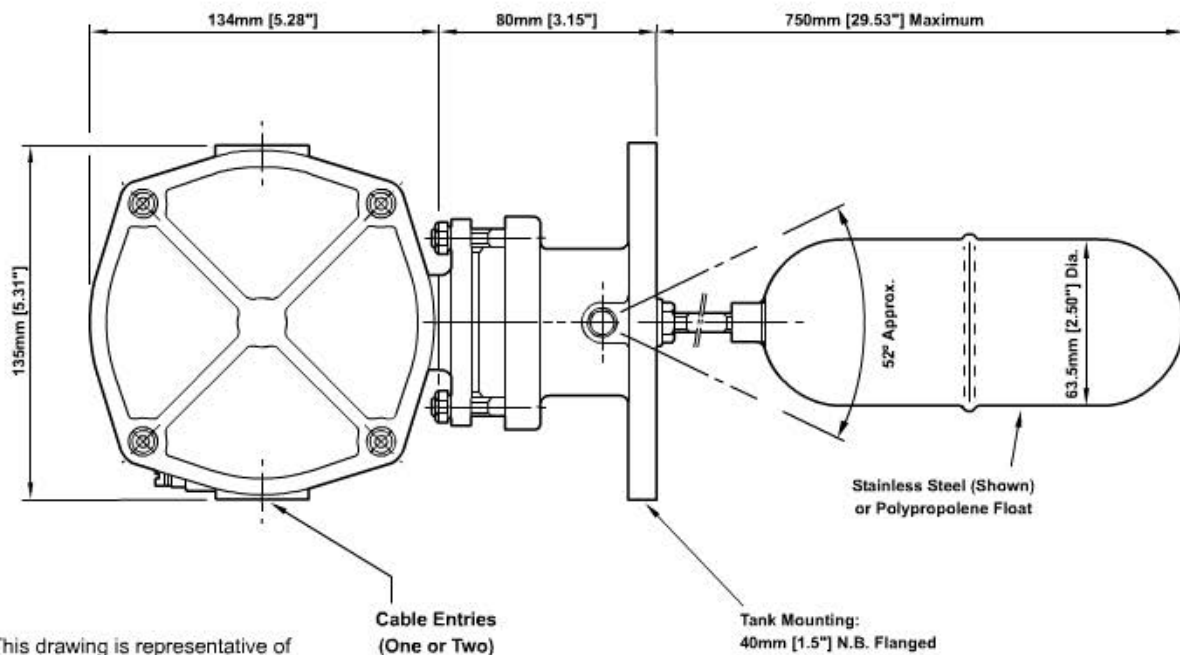

This drawing is representative of the range of switches available. Please consult the factory for a detailed drawing/specification sheet.