

GENERAL CHARACTERISTICS



The primary sensor is constituted by a propeller that enters in rotation with the passage of fluid. The speed of rotation is proportional to the flow rate. The measurement is detected by an inductive sensor. The body is transparent for a local view of the passage of the fluid. A version with blind body is available (TCO).

- Hermetic separation between flow chamber and sensor
- Good resolution and linearity
- Bi-directional operation
- IP67 protection



TECHNICAL DATA

Tab.1

Ø (*)	DN	PN bar	T max °C	Q max l/min (4)	Measuring range l/min			Pulses liter (6)	Hz (10)	Weight Kg		Code Measuring range	
					(1)	(2)	(3)			TCV	TCO		
3/8"	010	10	100	20	1,2 - 20	3 - 20	1,2 - 3	136	45	0,23	0,23	1,2 - 20	020
1/2"	015	10	100	40	1,2 - 40	3 - 40	1,2 - 3	128	86	0,23	0,23	1,2 - 40	040
3/4"	020	10	100	60	2,1 - 60	5 - 60	2,1 - 5	30	30	0,75	0,75	2,1 - 60	060
1"	025	10	100	80	2,1 - 80	5 - 80	2,1 - 5	35	48	0,65	0,65	2,1 - 80	080

(*) Thread UNI 228/1 – Female

1	Total measuring range	See measuring range table	
2	Linear measuring range	See measuring range table	
3	Non linear measuring range	See measuring range table	
4	Flow in excess of the value of F.S.	increased usury	$\Delta p > 0,5$ bar
5	Pulses / liter	Measurements with H ₂ O a 20°C	
6	Pulses / liter mean value	Detected with different sensors	
7	Accuracy	± 3%	Ref. to pulses / liter of measured value
8	Pulses / liter variation	± 10%	Ref. to the value at point 5
9	Repeatability	± 3%	Ref. to F.S. frequency
10	Max. frequency	Value at F.S.	

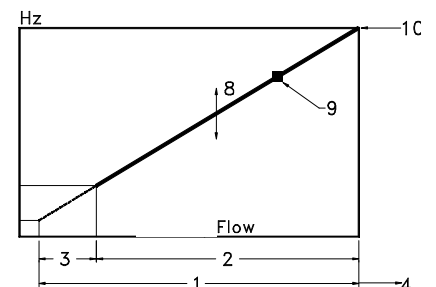
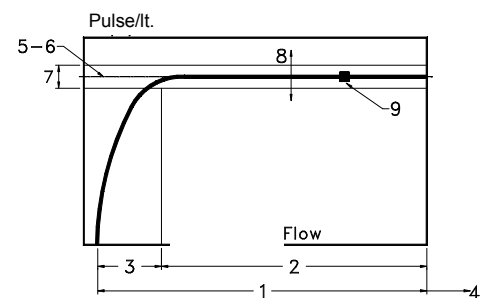
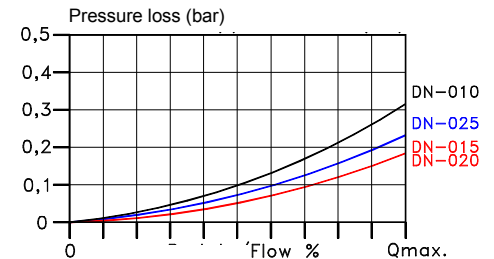

		Code	
		TCV	TCO
Type		Viewer pipe	Blind
Detection sensor		Inductive	Inductive
Power supply		10 – 30 Vdc	10 – 30 Vdc
Current		10 mA	10 mA
Max. load		200 mA	200 mA
Short circuit protection		Yes	Yes
Reverse polarity protection		Yes	Yes
Output	standard	P	PNP
	on request	N	NPN
Connection	S3	M12x1 - 4 poles	M12x1 - 4 poles
Degree of protection		IP67	IP67

MATERIALS Tab.2

		Code	
		PSO	PSK
Body		Latene	Latene
Process connections		Brass	S.S. AISI-316
Viewer pipe	TCV	Tempered glass	Tempered glass
Blind pipe	TCO	PA66 + GF	PA66 + GF
Rotor		Red PP	Red PP
Rotor inserts		N.2 stainless steel	N.2 stainless steel
Gaskets		NBR	Viton

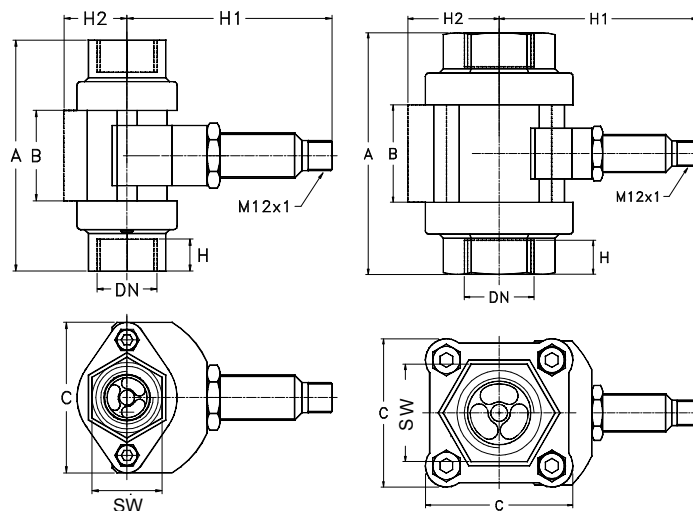

DN10 – DN15

DN20 – DN25

DIMENSIONS

DN	A	B	C	SW	H	H1
010	3/8"	92	36	60	28	15
015	1/2"	92	36	60	28	15
020	3/4"	114	46	70	46	20
025	1"	114	46	70	46	20

Dimensions in mm.

WIRING Tab.3

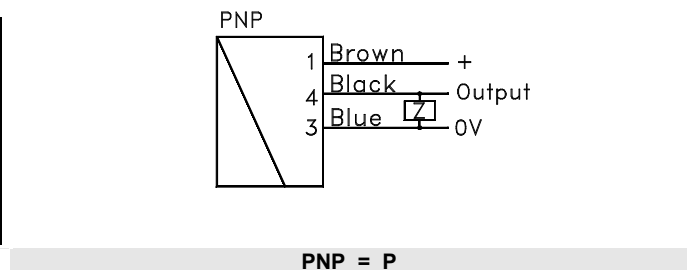
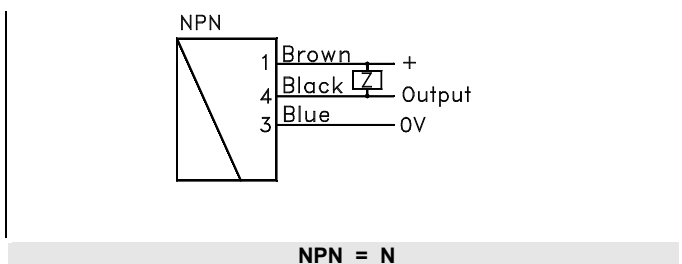

INSTALLATION

Before installing the transmitter the hydraulic circuit must be purged to avoid that contaminants can interfere with the proper functioning of the rotor. It is important that the rotor always work in conditions of clean fluid.

Attention: the presence of air bubbles in the fluid can be a source of error in the measurement. Valves and / or other auxiliary components of the circuit must be installed downstream of the transmitter. Electronic interface units are available to display the flow rate and the alarm signaling.

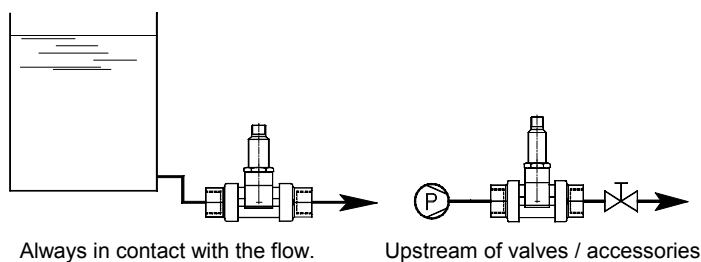

NOMENCLATURE

TCV	025	PSO	080	P	S3
•					
	•				
		•			
			•		
				•	
					•

Tab.1-2	Name - Type
Tab.1	Process connections - DN
Tab.2	Body and process connections material
Tab.1	Measuring range
Tab.1-3	Output signal and wiring
Tab.1	Electrical connection
K PU 02 S G	Connection cable 2m length with M12x1 plug
	Accessory on request