

GENERAL CHARACTERISTICS

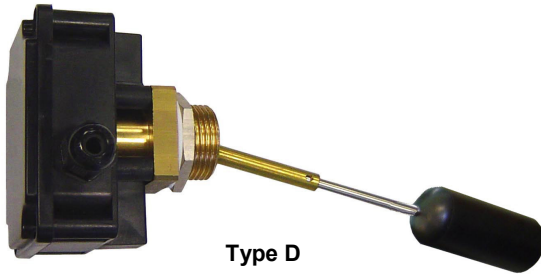

These level switches, with their reduced dimensions and simplicity of installation, constitute a reliable solution for the control of liquids in all applications where it is necessary to mount a lateral type. Suitable for use with process temperatures up to 120 °C.



Type D

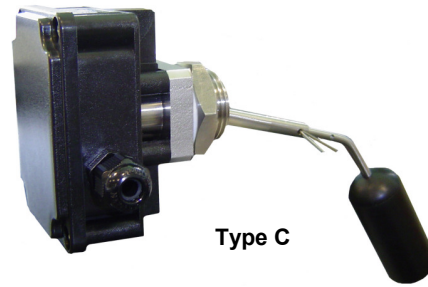

Type C

- 1 or 2 microswitches.
- Adjustable rod supporting float
- Executions in Brass and AISI-316
- Maximum working pressure 10 Bar
- Operating ambient temperature -30 /+55 °C - 90% RH
- Maximum working temperature 120 °C
- Degree of protection IP65

TECHNICAL DATA

Tab.1

Process connection	Float - B77	Max. pressure	Max. temperature	Hysteresis	Weight
Ø DN	S.G.	Bar	°C	mm	g
1" 25	0,4	10	120	max. 24	410

Male thread

G
Parallel UNI 228/1

Body materials

O	S
Brass	AISI-316
	On request

Float materials

B77	Rod
SPANSIL – Butadiene	AISI-303
Acrylonitrile Copolymer	

ELECTRICAL CONTACTS

Tab.2

Microswitch	TYPE		VOLTAGE		CURRENT	
	L1 = N.1	L2 = N.2	AC	DC	AC	DC
SPDT	7		250V	48	3A (cosφ=1)	3A

Wiring

I	3
Independent Separately wired microswitches	SPDT Changeover contacts

ELECTRICAL OUTPUT

Tab.3

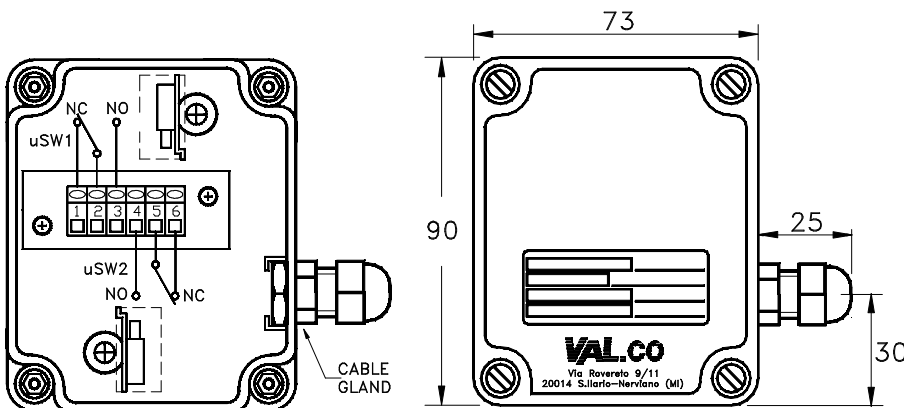

W IP65 Housing PA6 + glass fiber
6 terminals Polyamide cable gland PG9

SWITCH POINTS – ROD TYPE C

Tab.4

Switch points of the microswitches reported to the mechanical axis of the instrument with liquid having S.G. = 1

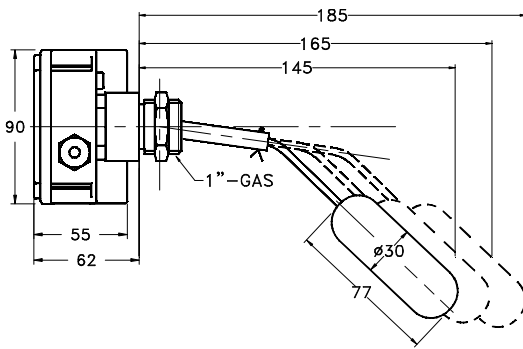

Rod length	Microswitch 1		Microswitch 2	
	ON	OFF	ON	OFF
Long	- 42	- 66	- 36	- 60
Medium	- 48	- 68	- 38	- 58
Short	- 52	- 70	- 38	- 56

General tolerances on the switch points ± 5 mm.
All measurements are in mm.

SWITCH POINTS ROD TYPE D

Tab.5

Switch points of the microswitches reported to the mechanical axis of the instrument with liquid having S.G. = 1

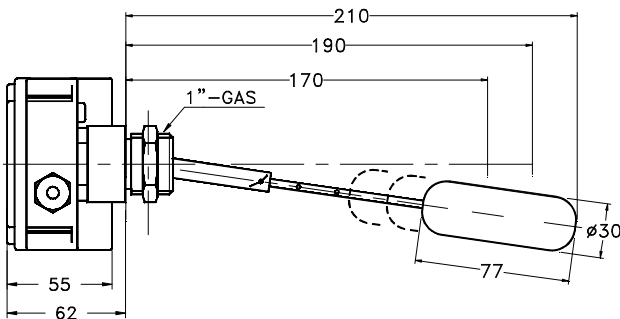

Rod length	Microswitch 1		Microswitch 2	
	ON	OFF	ON	OFF
Long	0	- 22	+ 22	0
Medium	0	- 19	+ 19	0
Short	0	- 17	+ 17	0

General tolerances on the switch points ± 5 mm.
All measurements are in mm.

ASSEMBLY AND INSTALLATION

Float assembly

- Remove the blocking pin from the rod of the float.
- Insert the rod of the float into the pipe and block it with the pin.
- The float can have 3 different positions depending on the tank and the desired switch point.
- Caution:** To avoid any type of damage to the float, during assembly, work always holding the rod, not the float itself.

Installation of the instrument in the tank

- Always insert the PTFE sealing gasket between the level control and the tank.
- Caution:** During installation, handle the level switch only by the electrical head without forcing the float.

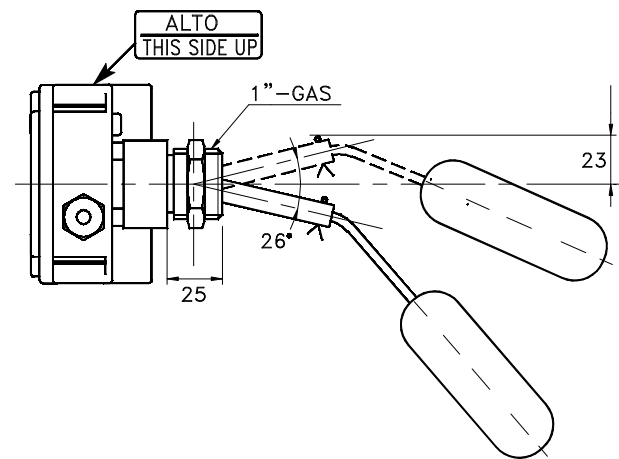

NOMENCLATURE

L2	B77	7	C	25	G	O	W	I33
•								
	•							
		•						
			•					
				•				
					•			
						•		
							•	
								•

Tab.2	Number of electrical contacts L1+ L2
Tab.1	Float
Tab.2	Type of the contacts
Tab.4-5	Type of the rod
Tab.1	Process connection dimension
Tab.1	Process connection thread
Tab.1	Process connection material
Tab.3	Electrical output
Tab.2	Wiring and contact status