

GENERAL CHARACTERISTICS

The level switches of the series P70 are made of polypropylene reinforced with glass fiber. The tanks in plastic materials and glass fiber are widely used in agriculture, chemical and civil plants.

These level switches offer the most reliable solution for controlling the level of liquid where is needed a device installed on the side of the tank. The small size, the materials and the facility of installation make this unit one of the more requested level switches by the market.

- Magnetic drive switch.
- Reed contact or solid state relay.
- Maximum working pressure 18 bar at 15 °C.
- Operating ambient temperature -20 / +55 °C - RH 90%
- Maximum operating temperature 80 °C.
- Degree of protection IP56

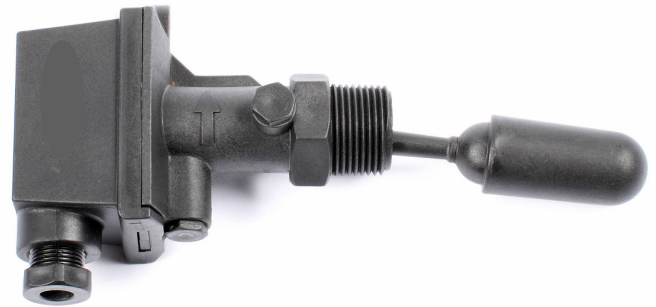

TECHNICAL DATA

Tab.1

| Process connection Ø | DN | Float - P70 S.G. | Max. pressure Bar | Max. temperature °C |
|-------------------------|----|---------------------|----------------------|------------------------|
| 1" | 25 | 0,8 | 18 | 80 |

Note: The temperature for the maximum working pressure indicated is 15 °C. The maximum working pressure should be decreased with increasing temperature.

Male thread – conical

| | |
|----------|-------------------|
| C | Conical – UNI 7/1 |
|----------|-------------------|

Body and float materials

| | |
|----------|---|
| P | Polypropylene Glass fiber reinforced |
|----------|---|

ELECTRICAL CONTACTS

Tab.2

| | TYPE | POWER | | VOLTAGE | | CURRENT | |
|----------|------------------------|-------|-----|---------|----|---------|----|
| | | VA | W | AC | DC | AC | DC |
| 7 | SPDT Reed contact | - | 40 | 250 | - | 1,0 | - |
| 0 | SPST Solid state relay | 100 | 750 | 250 | - | 5,2 (*) | - |

(*) Max. inductive load: 1HP / 0,75 KW / 100A max. peak current.

Wiring

| 1 | 3 | 0 |
|-------------|----------------------------|---------------------------|
| Independent | SPDT Changeover contact | SPST Solid state relay |

ELECTRICAL OUTPUT – DIMENSIONS in mm. Tab.3

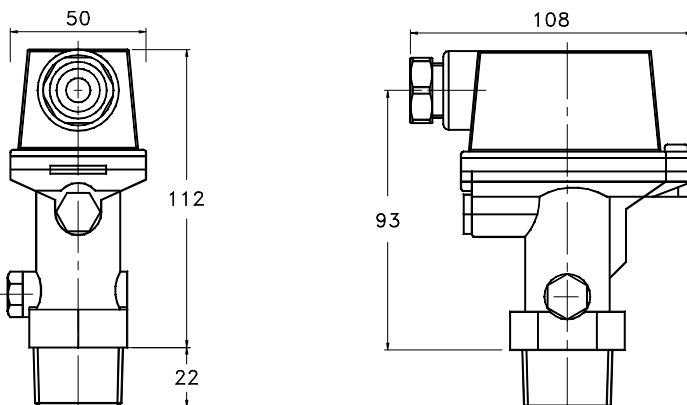

| |
|---|
| W IP56 Housing - PP + glass fiber |
| Acetalic terminal board Polyamide cable gland M20 x 1,5 |

DIMENSIONS – SWITCH POINT

Tab.4

The switch point of the instrument is reported to the mechanical axis with rising liquid and SG = 1.

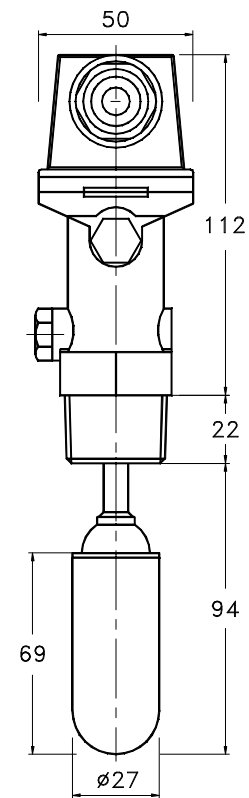
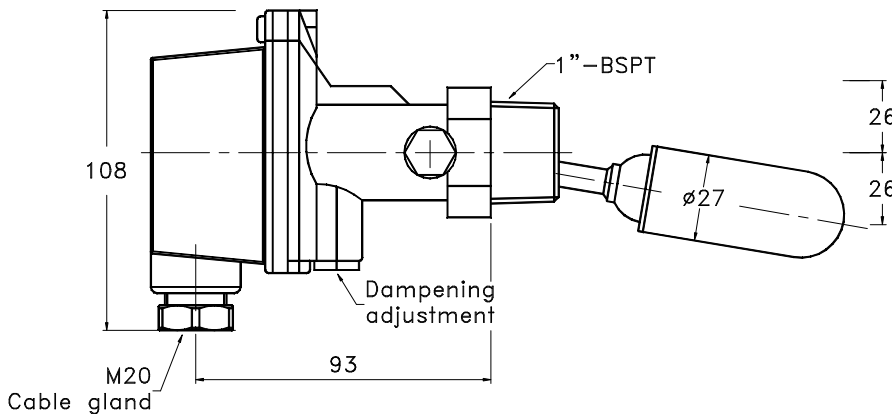

Switch point is approximately on the centreline of the instrument axis

MOUNTING AND INSTALLATION NOTES

- Install the instrument orthogonal to the tank.
- Provide a 1" Gas conical fitting on the side of the tank, positioned at the level to control.
- The float has dimensions suitable for the passage within a DN25 fitting.
- The instrument should be oriented for increasing or decreasing of the liquid to be controlled.
- The orientation is indicated by an arrow on the side of the instrument. The arrow, for a correct operation, must always remain vertical.
- In case of liquid with specific gravity of less than 1 (eg, diesel fuel), the arrow must point downwards. In this position the magnetic assembly increases the buoyancy of the system.
- **Caution:** During installation, handle the control level by the electrical head without forcing the float.

GENERAL NOTES

- Do not use this level switch where the temperature of the liquid is greater than 80 °C or below - 20 °C.
- With a temperature close to 80 °C the maximum working pressure of the switch (18 bar) must be reduced, preferably to less than 10 bar.
- With dangerous chemical solutions may be necessary to further reduce the operating limits of pressure and temperature.

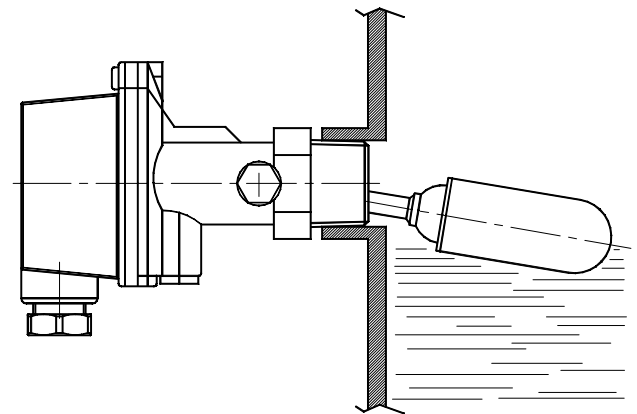

NOMENCLATURE

| L1 | P70 | 7 | 25 | C | P | W | I3 | | |
|----|-----|---|----|---|---|---|----|---------|------------------------------|
| • | | | | | | | | - | Type - N. 1 switch point |
| | • | | | | | | | Tab.1 | Float |
| | | • | | | | | | Tab.2 | Contact type |
| | | | • | | | | | Tab.1-4 | Process connection dimension |
| | | | | • | | | | Tab.1 | Process connection thread |
| | | | | | • | | | Tab.1 | Process connection material |
| | | | | | | • | | Tab.3 | Electrical output |
| | | | | | | | • | Tab.2 | Wiring |